

△ Reserve the right to change the parameters without prior notice.

VMC
Subsidiary of Meidensha Japan

VMC
Subsidiary of Meidensha Japan

Technology design by Subsidiary of Meidensha Japan Group

Technical support: support01@vmc-electric.com

Sales: sales01@vmc-electric.com

Website: vmc-electric.com



MCCB

Moulded Case Circuit Breaker

Committed to becoming a world-class manufacturer of intelligent electric

CONTENTS

MCCB SERIES

MCCB Fixed Type	01/04
MCCB Thermal Adjustable Type	05/08
MCCB Thermal & Magnetic Adjustable Type	09/12
MCCB Electronic Type With Button	13/17
MCCB Electronic Type With LCD	18/21
MCCB With ELCB Type	22/24
MCCB Accessories	25/41
DC Moulded Case Circuit Breaker	42/42
High Voltage AC Moulded Case Circuit Breaker	43/43
Smart Moulded Case Circuit Breaker	44/45

VMC
Subsidiary of Meidensha Japan

MCCB

Moulded Case Circuit Breaker



Product category	VGM series Moulded Case Circuit Breaker				
Design code	6				
Type code	Fixed Type ()	Thermal Adjustable Type (s)	Thermal & Magnetic Adjustable Type (sm)	Electronic Type with buttons (E) Electronic Type with LCD (i)	With ELCB Type (L)
Design code	125A,160A,250A,400A,630A,800A,1250A,1600A				
Breaking capacity level	L,M,H				
Pole	3,4				
Rated current	16-1600A				

e.g. : VGM 6 s - 125 M - 3 - 125



Fixed Type

VGM6 Moulded Case Circuit Breaker









Ratings And Specifications				Fixed Type																		
Frame Size																						
	125	160	250	400																		
Model	VGM6-125	VGM6-160	VGM6-250	VGM6-400																		
Number of poles	3,4																					
Rated current(A) In	16,20,25,30,32,40,50,60,63,70,75,80,90,100,125	30,32,40,50,60,70,75,80,90,100,125,140,150,160	100,125,140,150,160,175,180,200,225,250	250,280,300,315,350,400																		
Magnetic tripping current (Ii)	10*In for 40 - 125 A 330 A for 16 - 32A	10*In for 50 - 160 A 500 A for 30 - 40 A	10*In																			
Standard	IEC60947-2																					
Reference temperature	40°C/55°C																					
Rated operational voltage	380/400/415V AC																					
Rated insulation voltage Ui (V)	800				1000																	
Rated impulse withstand voltage Uimp (kV)	8																					
Breaking capacity level	L	M	H	L	M	H	L	M	H	M	H											
Rated ultimate short-circuit breaking capacity Icu(kA)	10	10	28	18	36	25	36	25	50	36	65	50	36	25	50	36	65	50	85	60	100	75
Rated service short-circuit breaking capacity Ics(kA)	10	18	25	25	36	50	25	36	50	60	75											
Icu / Ics	Icu = 100% Ics and Icu > 100% Ics																					
Mechanical Endurance	for 16-100A	for 125A	for 30-100A	for 125-160A	for 100A	for 125-250A	for 250-315A	for 350-400A														
Electrical Endurance	8500	7000	8500	7000	8500	7000	7000	4000	1500	1000	1500	1000	1000	1000								
Installation	Auxiliary contact(OF) Alarm switch(SD) Shunt trip(MX) Under-voltage release(MN) AC Motor Mechanism Extended Rotary Handle																					



Thermal Adjustable Type

VGM6s Moulded Case Circuit Breaker



Ratings And Specifications			Fixed Type									
Frame Size												
	630	800	1250	1600								
Model	VGM6-630	VGM6-800	VGM6-1250	VGM6-1600								
Number of poles	3,4											
Rated current(A) In	500,550,630	630,700,770,800	800,1000,1250	1000,1250,1600								
Magnetic tripping current (Ii)	10*In											
Standard	IEC60947-2											
Reference temperature	40°C/55°C											
Rated operational voltage	380/400/415V AC											
Rated insulation voltage Ui (V)	1000											
Rated impulse withstand voltage Uimp (kV)	8											
Breaking capacity level	M	H	M	H	M	M						
Rated ultimate short-circuit breaking capacity Icu(kA)	85	60	100	75	85	60	100	75	70	50	85	65
Rated service short-circuit breaking capacity Ics(kA)	60	75	60	75	50	65						
Icu / Ics	Icu = 100% Ics and Icu > 100% Ics											
Mechanical Endurance	4000		2500		2500		2500					
Electrical Endurance	1000		500		500		500					
Installation	Auxiliary contact(OF) Alarm switch(SD) Shunt trip(MX) Under-voltage release(MN) AC Motor Mechanism Extended Rotary Handle						Auxiliary contact(OF) Alarm switch(SD) Shunt trip(MX) Under-voltage release(MN) AC Motor Mechanism					

Ratings And Specifications		Thermal Adjustable Type														
Frame Size																
	125	160	250													
Model	VGM6s-125	VGM6s-160	VGM6s-250													
Number of poles	3,4															
Rated current(A) In	16,20,25,30,32,40,50,60,63,70,75,80,90,100,125	30,32,40,50,60,63,70,75,80,90,100,125,140,150,160	100,125,140,150,160,175,180,200,225,250													
Magnetic tripping current (li)	10*In for 40 - 125 A 330 A for 16 - 32 A	10*In for 50 - 160 A 500 A for 30 - 40 A	10*In													
Thermo-adjustable setting Ir(xIn)	0.8/0.9/1.0 or 0.7/0.85/1.0															
Standard	IEC60947-2															
Reference temperature	40°C/55°C															
Rated operational voltage	380/400/415V AC															
Rated insulation voltage Ui (V)	800	1000														
Rated impulse withstand voltage Uimp (kV)	8															
Breaking capacity level	M	H	L	M	H	L	M	H								
Rated ultimate short-circuit breaking capacity Icu(kA)	25	18	36	25	36	25	50	36	65	50	36	25	50	36	65	50
Rated service short-circuit breaking capacity Ics(kA)	18	25	25	36	50	25	36	50								
Icu / Ics	Icu = 100% Ics and Icu > 100% Ics															
Mechanical Endurance	for 16-100A	for 125A	for 30-100A	for 125-160A	for 100A	for 125-250A										
Electrical Endurance	8500 1500	7000 1000	8500 1500	7000 1000	8500 1500	7000 1000										
Installation	Auxiliary contact(OF) Alarm switch(SD) Shunt trip(MX) Under-voltage release(MN) AC Motor Mechanism Extended Rotary Handle															

Ratings And Specifications		Thermal Adjustable Type										
Frame Size												
	400	630	800									
Model	VGM6s-400	VGM6s-630	VGM6s-800									
Number of poles	3,4											
Rated current(A) In	250,280,300,315,350,400	400,500,550,630	630,700,770,800									
Magnetic tripping current (li)	10*In											
Thermo-adjustable setting Ir(xIn)	0.8/0.9/1.0											
Standard	IEC60947-2											
Reference temperature	40°C/55°C											
Rated operational voltage	380/400/415V AC											
Rated insulation voltage Ui (V)	1000											
Rated impulse withstand voltage Uimp (kV)	8											
Breaking capacity level	M	H	M	H	M	H						
Rated ultimate short-circuit breaking capacity Icu(kA)	85	60	100	75	85	60	100	75	85	60	100	75
Rated service short-circuit breaking capacity Ics(kA)	60	75	60	75	60	75	60	75				
Icu / Ics	Icu = 100% Ics and Icu > 100% Ics											
Mechanical Endurance	for 250-315A	for 350-400A	4000				2500					
Electrical Endurance	7000 1000	4000 1000	1000				500					
Installation	Auxiliary contact(OF) Alarm switch(SD) Shunt trip(MX) Under-voltage release(MN) AC Motor Mechanism											



Thermal & Magnetic Adjustable Type

VGM6sm Moulded Case
Circuit Breaker





Intelligence beyond vision

Ratings And Specifications Thermal & Magnetic Adjustable Type

Frame Size	 160		 250									
Model	VGM6sm-160		VGM6sm-250									
Number of poles	3,4											
Rated current(A) In	80,90,100, 125,140,150,160		100,125,140, 150,160,175, 180,200,225,250									
Magnetic tripping current (Ii)	10*In											
Thermo-adjustable setting Ir(λIn)	0.8/0.9/1.0 or 0.7/0.85/1.0											
Magnetic-adjustable setting Ii(λIn)	6-8-10											
Standard	IEC60947-2											
Reference temperature	40°C/55°C											
Rated operational voltage	380/400/415V AC											
Rated insulation voltage Ui (V)	1000											
Rated impulse withstand voltage Uimp (kV)	8											
Breaking capacity level	L	M	H	L	M	H						
Rated ultimate short-circuit breaking capacity Icu(kA)	36	25	50	36	65	50	36	25	50	36	65	50
Rated service short-circuit breaking capacity Ics(kA)	25		36		50		25		36		50	
Icu / Ics	Icu = 100% Ics and Icu > 100% Ics											
Mechanical Endurance Electrical Endurance	for 30-100A			for 125-160A			for 100A			for 125-250A		
	8500 1500			7000 1000			8500 1500			7000 1000		
Installation	Auxiliary contact(OF) Alarm switch(SD) Shunt trip(MX) Under-voltage release(MN) AC Motor Mechanism Extended Rotary Handle Fixed magnetic trip											

Ratings And Specifications Thermal & Magnetic Adjustable Type



Frame Size												
Model	VGM6sm-400	VGM6sm-630	VGM6sm-800									
Number of poles	3,4											
Rated current(A) In	250,280,300, 315,350,400	400,500,550, 630	630,700,770, 800									
Magnetic tripping current (Ii)	10*In											
Thermo-adjustable setting Ir(xIn)	0.8/0.9/1.0											
Magnetic-adjustable setting Ii(xIn)	6-8-10											
Standard	IEC60947-2											
Reference temperature	40°C/55°C											
Rated operational voltage	380/400/415V AC											
Rated insulation voltage Ui (V)	1000											
Rated impulse withstand voltage Uimp (kV)	8											
Breaking capacity level	M	H	M	H	M	H						
Rated ultimate short-circuit breaking capacity Icu(kA)	85	60	100	75	85	60	100	75	85	60	100	75
Rated service short-circuit breaking capacity Ics(kA)	60	75	60	75	60	75	60	75	60	75	60	75
Icu / Ics	Icu = 100% Ics and Icu > 100% Ics											
Mechanical Endurance	for 250-315A		for 350-400A		4000				2500			
Electrical Endurance	7000		4000		1000				500			
Installation	Auxiliary contact(OF) Alarm switch(SD) Shunt trip(MX) Under-voltage release(MN) AC Motor Mechanism Fixed magnetic trip											

Electronic Type With Button

VGM6E Moulded Case
Circuit Breaker



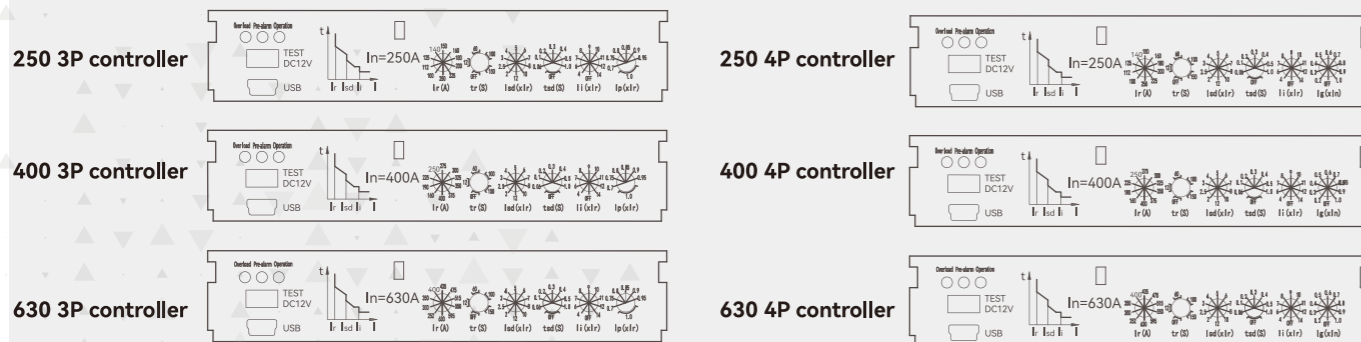

Ratings And Specifications Electronic Type With Button

Frame Size														
	250	400	630											
Model	VGM6E-250	VGM6E-400	VGM6E-630											
Number of poles	3,4													
Rated current(A) In	125,160,250	250,400	250,400,630											
Standard	IEC60947-2													
Rated operational voltage	380/400/415V AC													
Rated insulation voltage Ui (V)	1000													
Rated impulse withstand voltage Uimp (kV)	8													
Breaking capacity level	L	M	H	M	H	M	H							
Rated ultimate short-circuit breaking capacity Icu(kA)	36	25	50	36	65	50	85	60	100	75	85	60	100	75
Rated service short-circuit breaking capacity Ics(kA)	25	36	50	60	75	60	75	60	75	60	75	60	75	60
Icu / Ics	Icu = 100% Ics and Icu > 100% Ics													
Mechanical Endurance	for 100A	for 125-250A	for 250-315A	for 350-400A	4000									
Electrical Endurance	8500	7000	7000	4000	1000									
Installation	Auxiliary contact(OF) Alarm switch(SD) Shunt trip(MX) Under-voltage release(MN) AC Motor Mechanism Extended Rotary Handle													



Ratings And Specifications Electronic Type With Button

Frame Size								
	800	1250	1600					
Model	VGM6E-800	VGM6E-1250	VGM6E-1600					
Number of poles	3,4							
Rated current(A) In	630,800	1000,1250	1000,1250,1600					
Standard	IEC60947-2							
Reference temperature	40°C/55°C							
Rated operational voltage	380/400/415V AC							
Rated insulation voltage Ui (V)	1000							
Rated impulse withstand voltage Uimp (kV)	8							
Breaking capacity level	M	H	M	M				
Rated ultimate short-circuit breaking capacity Icu(kA)	85	60	100	75	70	50	85	65
Rated service short-circuit breaking capacity Ics(kA)	60	75	50	65	60	75	50	65
Icu / Ics	Icu = 100% Ics and Icu > 100% Ics							
Mechanical Endurance	2500							
Electrical Endurance	500							
Installation	Auxiliary contact(OF) Alarm switch(SD) Shunt trip(MX) Under-voltage release(MN) AC Motor Mechanism Extended Rotary Handle							

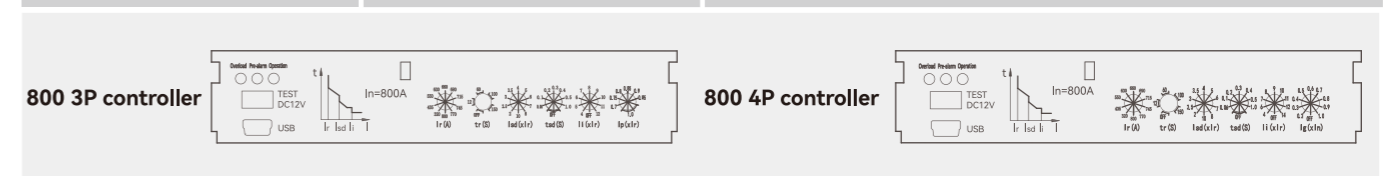



Setting Parameters				Electronic Type With Button						
Frame Size	250A			400A		630A		800A		
Rated current In(A)	125	160	250	250	400	250	400	630	630	800
Ir(A) Long Delay Current Setting	50-63-70 75-80-85 90-95-100 125A	63-70-75 80-90-100 125-140-150 160A	100-112-125-140-150 160-180-200-225-250A	160-190-225 250-275 300-325-350 375-400A	100-112-125 140-150 160-180-200 225-250A	160-190-225 250-275 300-325-350 375-400A	252-300-350-400-435 475-515-550-595-630A	320-435-550 630-660 690-715-745 770-800A		
tr(S) Long Delay Time	12-60-100-150 sec + OFF									
Isd(A) Short Circuit Protection Of Low Level Faults	2-2.5-3-4-5-6-7-8-10-12 x Ir(A)									
tsd (S) short time	0.06-0.1-0.2-0.3 sec + OFF			0.06-0.1-0.3- 0.4-0.5-1.0 sec + OFF						
Ii(A) Short Circuit Protection Of High level Faults	4-6-7-8-9-10-11-12-14 xIr(A) + OFF			4-5-6-7-8-9 10-11-12-14 xIr(A) + OFF		4-6-7-8-9-10-11-12-14 xIr(A) + OFF		4-5-6-7-8-9 10-11-12 xIr(A) + OFF		
I _p (A) Pre Trip Alarm Setting Multiple	0.7-0.75-0.8-0.85-0.9-0.95 1.0 x Ir(A)									
For 4p I _g (A) Ground Fault Pickup Current	0.2-0.3-0.4-0.5-0.6-0.7-0.8-0.9 1.0 x In+ OFF									
For 4p t _g (S) Ground Fault Pickup Time	Fixed for 0.4sec									

Electronic Type With LCD

iVGM6E Moulded Case
Circuit Breaker



Ratings And Specifications Electronic Type With LCD

Frame Size								
	400		630		800			
Model	iVGM6E-400		iVGM6E-630		iVGM6E-800			
Number of poles	3,4							
Rated current(A) In	250,400		250,400,630		630,800			
Standard	IEC60947-2							
Reference temperature	40°C/55°C							
Rated operational voltage	380/400/415V AC							
Rated insulation voltage Ui (V)	1000							
Rated impulse withstand voltage Uimp (kV)	8							
Breaking capacity level	M	H	M	H	M	H		
Rated ultimate short-circuit breaking capacity Icu(kA)	85	60	100	75	85	60	100	75
Rated service short-circuit breaking capacity Ics(kA)	60	75	60	75	60	75		
Icu / Ics	Icu = 100% Ics and Icu > 100% Ics							
Mechanical Endurance	for 250-315A	for 350-400A	4000		2500			
Electrical Endurance	7000	4000	1000		500			
Installation	Auxiliary contact(OF) Alarm switch(SD) Shunt trip(MX) Under-voltage release(MN) AC Motor Mechanism Extended Rotary Handle							

Setting Parameters Electronic Type With LCD

Frame Size	400A		630A		800A		
Rated current In(A)	250	400	250	400	630	630	800
Ir(A) Long Delay Current Setting	100-250A in steps of 1A	160-400A in steps of 1A	100-250A in steps of 1A	160-400A in steps of 1A	252-630A in steps of 1A		320-800A in steps of 1A
tr(S) Long Delay Time	12-150sec in steps of 1 sec+OFF						
Isd(A) Short Circuit Protection Of Low Level Faults	200-3000A in steps of 1A	320-4800A in steps of 1A	200-3000A in steps of 1A	320-4800A in steps of 1A	504-7560A in steps of 1A		640-9600A in steps of 1A
tsd (S) short time	0.06-1sec in steps of 0.02 sec+OFF						
Ii(A) Short Circuit Protection Of High level Faults	400-3500A in steps of 1A + OFF	640-5600A in steps of 1A + OFF	400-3500A in steps of 1A + OFF	640-5600A in steps of 1A + OFF	1008- 8820A in steps of 1A + OFF		1280-9600A in steps of 1A + OFF
Ip(A) Pre Trip Alarm Setting Multiple	70-250A in steps of 1A	112-400A in steps of 1A	70-250A in steps of 1A	112-400A in steps of 1A	175-630A in steps of 1A	175-630A in steps of 1A	224-800A in steps of 1A
For 4p Ig(A) Ground Fault Pickup Current	50-250A in steps of 1A + OFF	80-400A in steps of 1A + OFF	50-250A in steps of 1A + OFF	80-400A in steps of 1A + OFF	126-630A in steps of 1A + OFF		160-800A in steps of 1A + OFF
For 4p tg(S) Ground Fault Pickup Time	Fixed for 0.4sec						

MCCB With ELCB Type





VGM6L Moulded Case Circuit Breaker



Intelligence beyond vision

Ratings And Specifications

MCCB With ELCB Type

Frame Size	   																					
Model	VGM6L-250	VGM6L-400	VGM6L-630	VGM6L-800																		
Number of poles	4																					
Rated current(A) In	100,125,140,160,180,200,225	225,250,315,350,400	400,500,630	630,700,800																		
Standard	IEC60947-2																					
Rated insulation voltage Ui (V)	800																					
Rated impulse withstand voltage Uimp (kV)	8																					
Breaking capacity level	L	M	L	M	H	L	M	H	L	M	H											
Rated ultimate short-circuit breaking capacity Icu(kA)	35	22	50	35	50	35	62	42	100	65	50	35	65	42	100	68	50	35	65	42	100	65
Rated service short-circuit breaking capacity Ics(kA)	22		35		35		42		65		35		42		65		35		42		65	
Icu / Ics	Icu = 100% Ics and Icu > 100% Ics																					
Mechanical Endurance	for 100A				for 125-250A				for 250-315A				for 350-400A				4000					
Electrical Endurance	8500				7000				7000				4000				1000					
Rated residual operating current IΔn(mA)																						
Without time delay	30/100/500				100/300/500				100/300/500				300/500/1000				300/500/1000					
With time delay	100/300/500																					
Rated residual non-operating current	1/2 IΔn																					
Breaking time at a residual current	2IΔn				5IΔn				5IΔn				10IΔn				10IΔn					
Without time delay	0.15				0.15				0.15				0.04				0.04					
With time delay	0.4/1																					
Installation	Straight extension bars(FB) Spread extension bars(FB) Rear connection(RC) Phase barrier																					

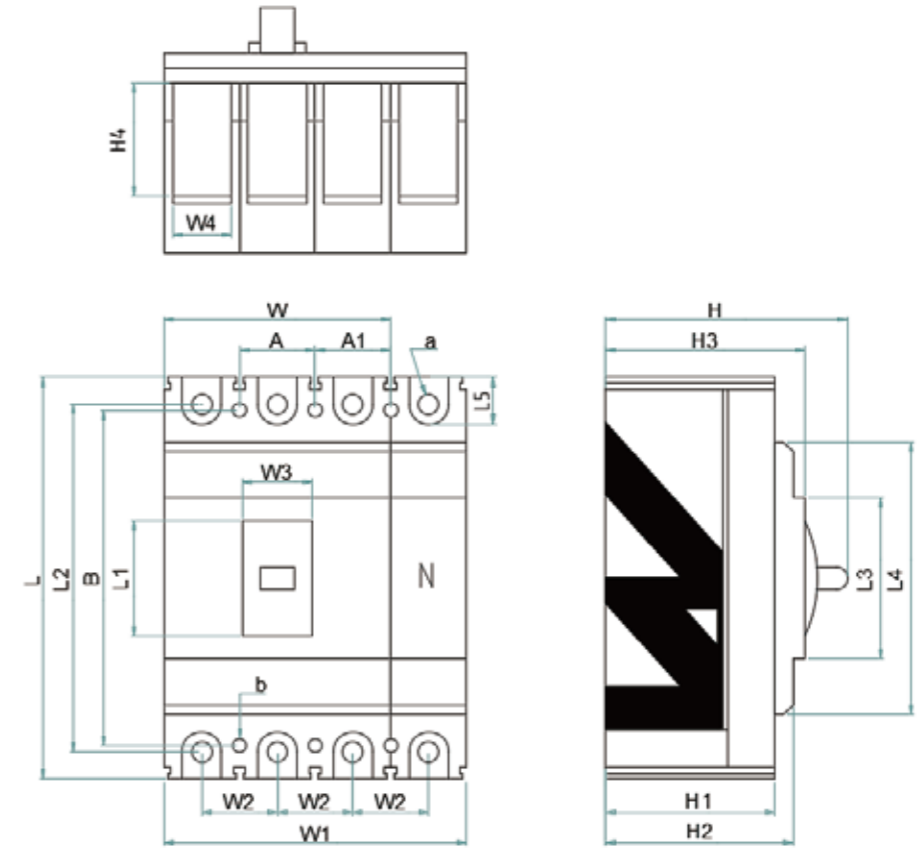
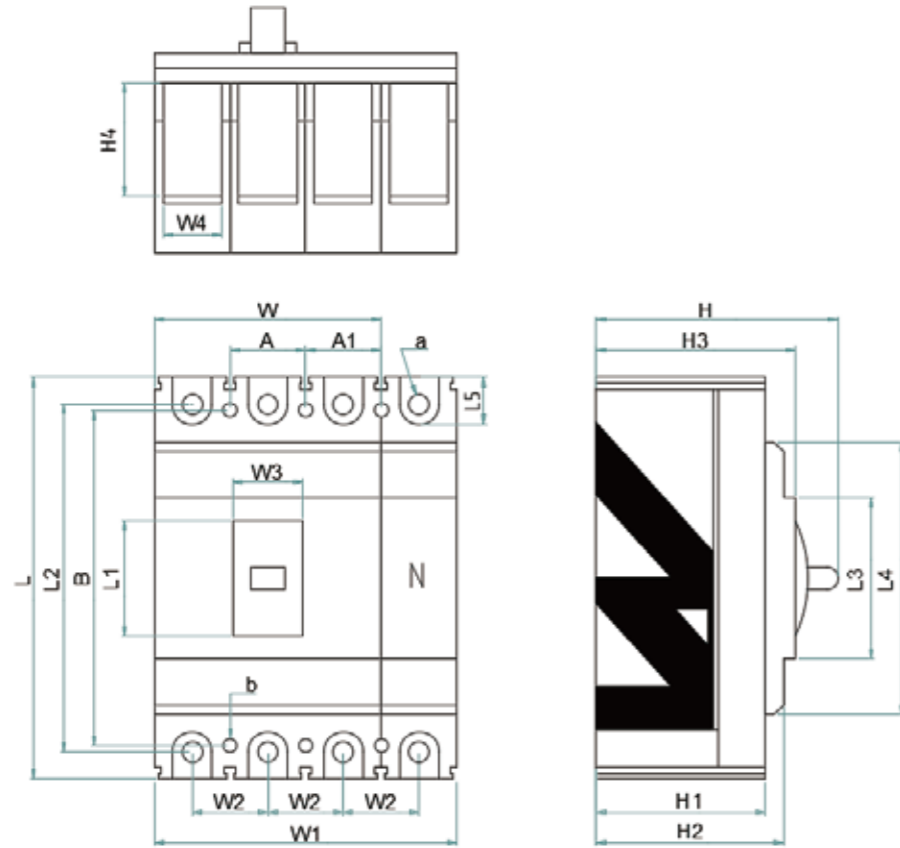

Frame Size	Installation dimensions (mm)			Dimensions (mm)				
	A	A1	B	L	W	W1	H	L2
VGM - 125	25	25	111	133	75	100	81	115
VGM - 160	30	30	122	155	92	122	92	135
VGM - 250	35	35	126	165	107	142	98	147.2
VGM - 400	43.5	43.5	194	257	140	182.5	148.5	224.8
VGM - 630	44	44	194	257	150	197	152	224
VGM - 800	70	70	245	280	210	280	155	243
VGM - 1 25 0	70	70	245	310	212	282	242	279.5
VGM - 1600	70	70	245	310	212	282	242	279.5

Dimensions (mm)											
L3	L4	L5	W2	W3	W4	H1	H2	H3	H4	a	b
52.5	90	17	25	23	16	56	56	66	25	M8	Ø4.2
60	101.5	20	30	29.5	17	61	69	74	35	M8	Ø4.2
60	110.4	19.9	35	32.8	23	63	69.5	75.6	37.2	M8	Ø4.2
84	174.5	28	43.5	31	55	97.5	105.5	112.5	53.5	M10	Ø7.5
86.5	174	28	48	33	54	98.5	105.5	113	48	M10	Ø7.5
87	199	33	70	58	44	103	116	118	42	M12	Ø7.5
103	226	30	70	81	54	156	163	168	67	M10	Ø6.5
103	226	30	70	81	54	156	163	168	67	M10	Ø6.5

MCCB Accessories

Internal Accessories
External Accessories

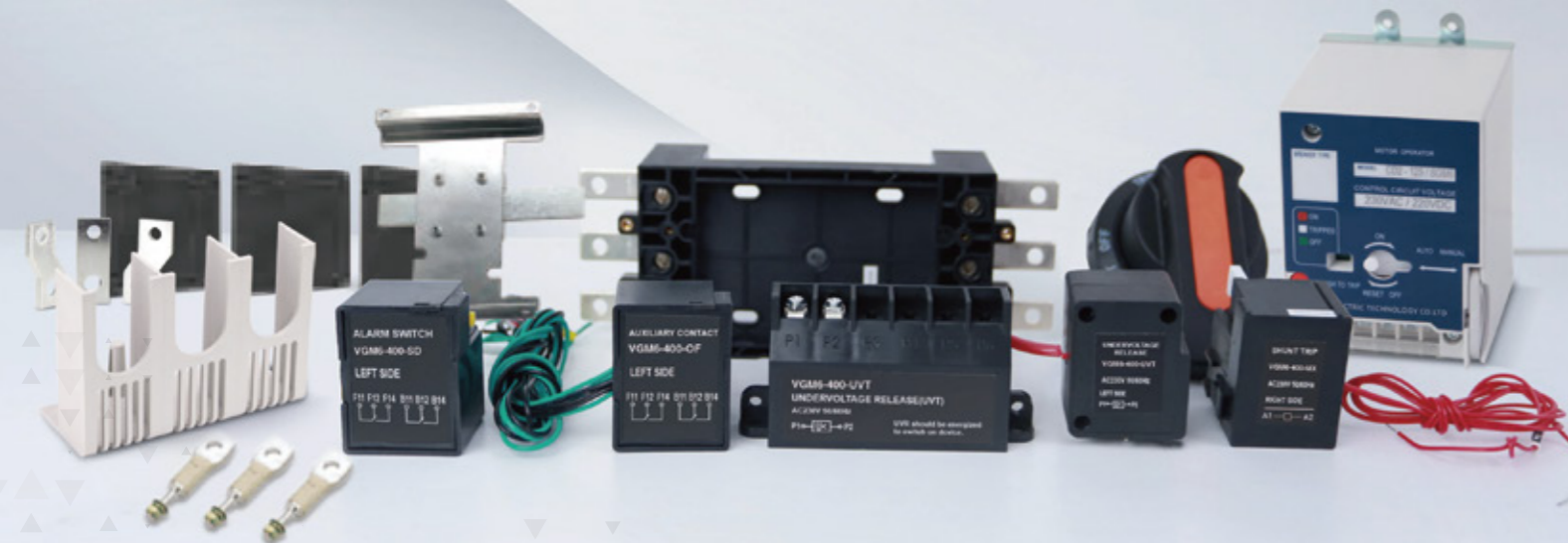

Accessories

Overview of Accessories

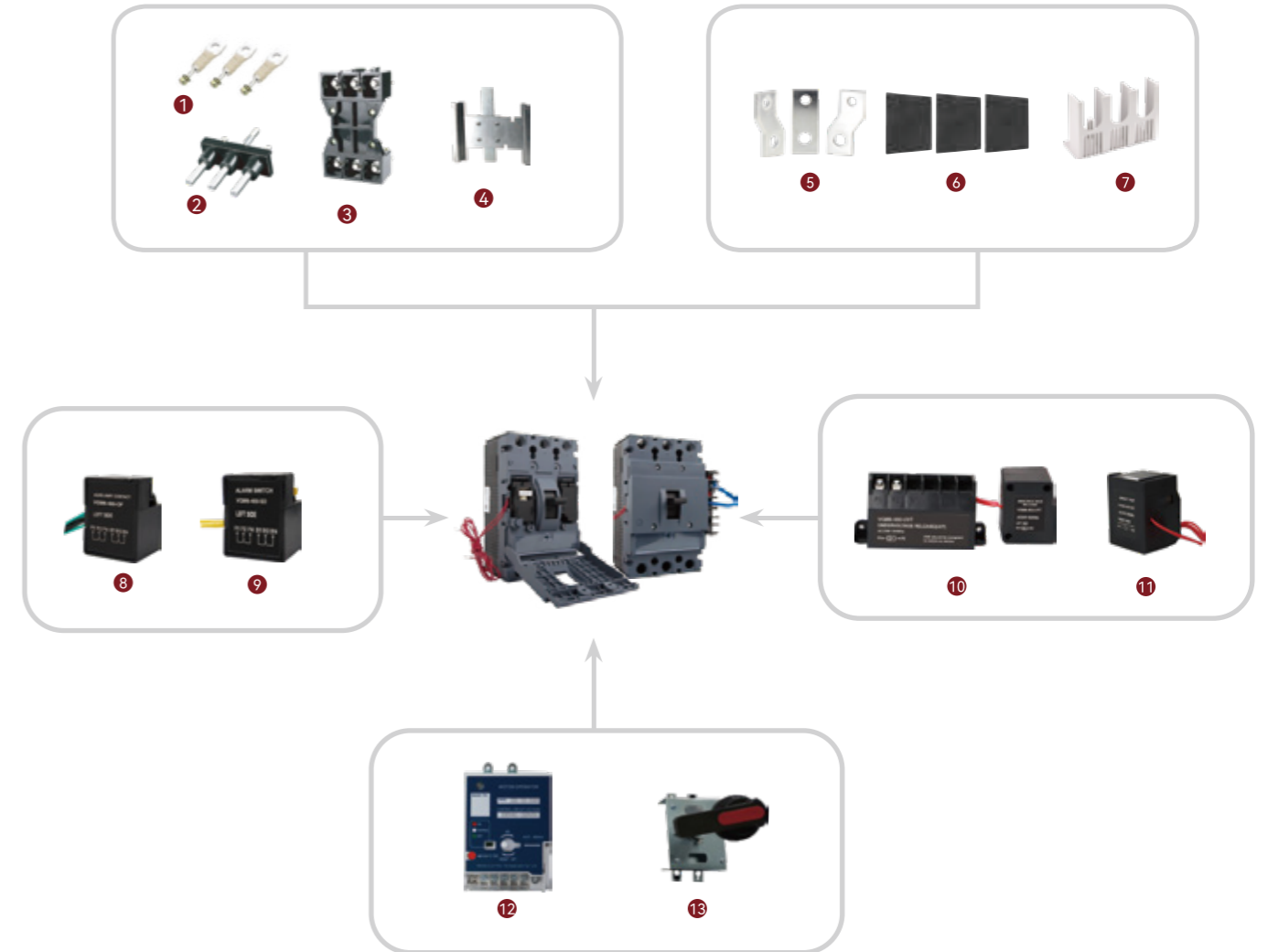

- | | | | |
|---|--------------------------|----|----------------------------------|
| 1 | Fixed rear connection | 8 | Auxiliary contact |
| 2 | Plug-in rear connection | 9 | Alarm contact |
| 3 | Plug-in front connection | 10 | Under-voltage release |
| 4 | Mechanical interlock | 11 | Shunt release |
| 5 | Spreader links | 12 | Electric operating mechanism |
| 6 | Interphase barriers | 13 | Round handle operating mechanism |
| 7 | Terminal cover | | |

Internal Accessories

■ Auxiliary contact



An accessory connected in the auxiliary circuit of the switching device to indicate the circuit breaker status of ON or not.

Electrical wiring diagram

Accessory name	ON	OFF/TRIP
Auxiliary		

Electrical parameters

Conventional Thermal Current	3A		
Use category		AC 15	DC 13
Working electricity 50Hz	AC 400V	0.3A	
	DC 220V		0.15A

■ Alarm contact



An accessory used to indicate the circuit breaker status of ON or not. When the alarm contact indicates that the circuit breaker is at Trip status, there are the following five possibilities.

- Overload or short circuit fault.
- Shunt release action.
- Residual current fault.
- Line fault and undervoltage release action.

Electrical wiring diagram

Accessory name	ON/OFF	TRIP
Alarm		

Electrical parameters

Conventional Thermal Current	3A		
Use category		AC 15	DC 13
Working electricity 50Hz	AC 400V	0.3A	
	DC 220V		0.15A

Internal Accessories

■ Shunt release



- The shunt release shall reliably trip the circuit breaker at the voltage between 70% and 110% of the rated control power voltage U_e .
- The circuit breaker shall be reset on the site after tripping through the shunt release.

Electrical wiring diagram

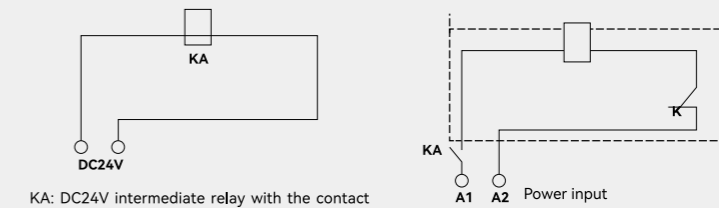

KA: DC24V intermediate relay with the contact current capacity of 1A

Electrical parameters

Frame size	Shunt release power loss(W)		
	AC400V	AC230V	DC24V
VGM6-125	152	161	180
VGM6-160	116	225	165
VGM6-250	220	161	108
VGM6-400/630/800	108	179	98

■ Under-voltage release



- The undervoltage release shall reliably trip the circuit breaker at the voltage between 35% and 70% of the rated operational voltage;
- The undervoltage release shall ensure that the circuit breaker can be switched on at the voltage between 85% and 110% of the rated operational voltage;
- The undervoltage release shall prevent the circuit breaker from switching on when voltage is below 35% of the rated operational voltage.

Electric wiring diagram

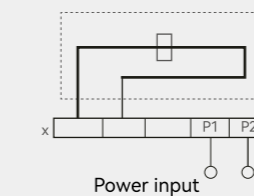

Note: X- terminal block

Note: In the dashed box, it is the wiring diagram of accessories in the circuitbreaker.

Electrical parameters

Frame size	Undervoltage release power loss(W)	
	AC400V	AC230V
VGM6-125	124	41
VGM6-160	4	2.4
VGM6-250	4	2.4
VGM6-400/630/800	224	184

Accessories Selection Guide

■ Auxiliary contact with Wire

Auxiliary contact	Frame size	Contact	Left	Right
	VGM6-125	1NC+1NO	VGM6125OF11L	VGM6125OF11R
		2NC+2NO	VGM6125OF21L	VGM6125OF21R
	VGM6-160	1NC+1NO	VGM6160OF11L	VGM6160OF11R
		2NC+2NO	VGM6160OF21L	VGM6160OF21R
	VGM6-250	1NC+1NO	VGM6250OF11L	VGM6250OF11R
		2NC+2NO	VGM6250OF21L	VGM6250OF21R
	VGM6-400/630/800	1NC+1NO	VGM6***OF11L	VGM6***OF11R
		2NC+2NO	VGM6***OF21L	VGM6***OF21R

***: 400 or 630 or 800

■ Alarm contact with Wire

Alarm contact	Frame size	Left	Right
	VGM6-125	VGM6125SD1L	VGM6125SD1R
	VGM6-160	VGM6160SD1L	VGM6160SD1R
	VGM6-250	VGM6250SD1L	VGM6250SD1R
	VGM6-400/630/800	VGM6***SD1L	VGM6***SD1R

***: 400 or 630 or 800

■ Auxiliary + Alarm with Wire

Auxiliary + Alarm	Frame size	Left	Right
	VGM6-125	VGM6125OFSD1L	VGM6125OFSD1R
	VGM6-160	VGM6160OFSD1L	VGM6160OFSD1R
	VGM6-250	VGM6250OFSD1L	VGM6250OFSD1R
	VGM6-400/630/800	VGM6***OFSD1L	VGM6***OFSD1R

***: 400 or 630 or 800

Accessories Selection Guide

■ Shunt release with Wire

Shunt release	Frame size	Voltage	Left	Right
	VGM6-125	AC230V	VGM6125MXAC2L	VGM6125MXAC2R
		AC400V	VGM6125MXAC3L	VGM6125MXAC3R
		DC110V	VGM6125MXDC1L	VGM6125MXDC1R
		DC220V	VGM6125MXDC2L	VGM6125MXDC2R
	VGM6-160	DC24V	VGM6125MXDC3L	VGM6125MXDC3R
		AC230V	VGM6160MXAC2L	VGM6160MXAC2R
		AC400V	VGM6160MXAC3L	VGM6160MXAC3R
		DC110V	VGM6160MXDC1L	VGM6160MXDC1R
	VGM6-250	DC220V	VGM6160MXDC2L	VGM6160MXDC2R
		DC24V	VGM6160MXDC3L	VGM6160MXDC3R
		AC230V	VGM6250MXAC2L	VGM6250MXAC2R
		AC400V	VGM6250MXAC3L	VGM6250MXAC3R
	VGM6-400/630/800	DC110V	VGM6250MXDC1L	VGM6250MXDC1R
		DC220V	VGM6250MXDC2L	VGM6250MXDC2R
		DC24V	VGM6250MXDC3L	VGM6250MXDC3R
		AC230V	VGM6***MXAC2L	VGM6***MXAC2R
		AC400V	VGM6***MXAC3L	VGM6***MXAC3R
		DC110V	VGM6***MXDC1L	VGM6***MXDC1R
		DC220V	VGM6***MXDC2L	VGM6***MXDC2R
		DC24V	VGM6***MXDC3L	VGM6***MXDC3R

***: 400 or 630 or 800

■ Under voltage release with Terminal

Under voltage release	Frame size	Voltage	Left	Right
	VGM6-125	AC230V	VGM6125MNAC2L	VGM6125MNAC2R
		AC400V	VGM6125MNAC3L	VGM6125MNAC3R
		DC110V	VGM6125MNDC1L	VGM6125MNDC1R
		DC220V	VGM6125MNDC2L	VGM6125MNDC2R
	VGM6-160	DC24V	VGM6125MNDC3L	VGM6125MNDC3R
		AC230V	VGM6160MNAC2L	VGM6160MNAC2R
		AC400V	VGM6160MNAC3L	VGM6160MNAC3R
		DC110V	VGM6160MNDC1L	VGM6160MNDC1R
	VGM6-250	DC220V	VGM6160MNDC2L	VGM6160MNDC2R
		DC24V	VGM6160MNDC3L	VGM6160MNDC3R
		AC230V	VGM6250MNAC2L	VGM6250MNAC2R
		AC400V	VGM6250MNAC3L	VGM6250MNAC3R
	VGM6-400/630/800	DC110V	VGM6250MNDC1L	VGM6250MNDC1R
		DC220V	VGM6250MNDC2L	VGM6250MNDC2R
		DC24V	VGM6250MNDC3L	VGM6250MNDC3R
		AC230V	VGM6***MNAC2L	VGM6***MNAC2R
		AC400V	VGM6***MNAC3L	VGM6***MNAC3R
		DC110V	VGM6***MNDC1L	VGM6***MNDC1R
		DC220V	VGM6***MNDC2L	VGM6***MNDC2R
		DC24V	VGM6***MNDC3L	VGM6***MNDC3R

***: 400 or 630 or 800

External Accessories

■ Rear connection



Easy to install and connect the products in the rear connection.

■ Plug-in

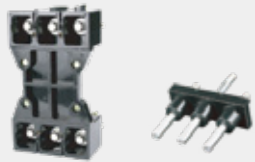

Plug-in

The wiring type is divided into plug-in Rear Connection and plug-in Front Connection. The plug-in connection for the products is easy for maintenance and replacement, but plug-in and plug-out cannot be done with the electricity.

Frame size	Fixed front	Fixed rear	Plug-in front	Plug-in rear
VGM6-125	■	■	■	■
VGM6-160	■	■	■	■
VGM6-250	■	■	■	■
VGM6-400	■	■	■	■
VGM6-630	■	■	■	■
VGM6-800	■	■	■	■

■ Mechanical interlock



Mechanical interlock is intended to prohibit both power sources from being simultaneously connected to the load. The interlocking system disables one circuit breaker by mechanically preventing handle movement from the Off position while the other circuit breaker is in the On position.

■ Spreader links



The spreader links are connected to the terminal of the circuit breaker, in order to provide many other wiring schemes in the limited space:

- Direct spreader links
- Spreader link with inter-electrode distance

The busbar and extension terminal can be connected to the inlet or outlet terminal of the circuit breaker.

■ Interphase barriers



The interphase barriers can enhance the insulating performances between phase and phases. They can be installed from the product front even though the products had mounted. Interphase barriers will be offered by standard, 3P product(4pcs), 4P product(6pcs).

External Accessories

■ Terminal cover



Protection Degree: IP40
Protect from being contacted with main circuit.

■ Motor



- Apply to remote electric connection, disconnection and re-trip of the circuit breaker and the automation control occasions.
- Rated voltage of electric operating mechanism: AC400V;AC230V/DC220V;AC/DC110V;DC24V
- Operating voltage range of electric operating mechanism: 85%-110% Ue.

Electrical wiring diagram

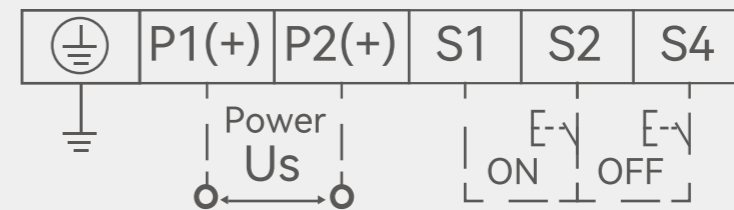

- When operating manually, operate 180° clockwise and do not operate counter clockwise.
- Withstand voltage test: it should be between the incoming terminals P1 and P2 (excluding S1, S2 and S4) of the power supply and the installation screws of electric operation that can withstand 50Hz AC, power Frequency withstand voltage test of 1890V (withstand voltage test is prohibited when rated voltage is DC24V).
- P1 and P2 are forbidden to be connected to S1, S2 and S4 during electrical operation.

Electrical parameters

Frame size	IP degree	Current	Voltage	Switch on/off time	Electric life
VGM6-125	20	≤0.5 DC24V≤3	AC110V/DC110V AC230V/DC220V AC400V DC24V	≤0.7	10000
VGM6-160/250	20	≤0.8 DC24V≤3			10000
VGM6-400/630/800	20	≤1 DC24V≤6		≤1	5000

■ Round handle



Handle operating mechanism

The circuit breaker can be operated by the rotation of the handle and the ergonomically designed rotation handle makes the operation of the circuit breaker more flexible.

User visualization information/settings:

- 3 position indications: OFF, ON and TRIP
- The circuit breaker cannot be switched on when the door is open
- The door cannot be opened when the circuit breaker is switched on
- The axial length of the extended handle can be custom made according to the distance from the back of the circuit breaker to the door.

Accessories Selection Guide

■ Rear connection

Rear connection	Frame size	3P(6pcs)	4P(8pcs)
	VGM6-125	VGM6125RC3	VGM6125RC4
	VGM6-160	VGM6160RC3	VGM6160RC4
	VGM6-250	VGM6250RC3	VGM6250RC4
	VGM6-400/630	VGM6***RC3	VGM6***RC4
	VGM6-800	VGM6800RC3	VGM6800RC4

***: 400 or 630

■ Plug-in

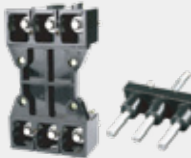
Plug-in	Frame size	Connection type	3P	4P
	VGM6-125	Front connection	VGM6125PF3	VGM6125PF4
		Rear connection	VGM6125PR3	VGM6125PR4
	VGM6-160	Front connection	VGM6160PF3	VGM6160PF4
		Rear connection	VGM6160PR3	VGM6160PR4
	VGM6-250	Front connection	VGM6250PF3	VGM6250PF4
		Rear connection	VGM6250PR3	VGM6250PR4
	VGM6-400/630	Rear connection	VGM6***PR3	VGM6***PR4
	VGM6-800	Rear connection	VGM6800PR3	VGM6800PR4

***: 400 or 630

■ Spreader links

Spreader links	Frame size	3P(3pcs)	4P(4pcs)
	VGM6-125	VGM6125C3	VGM6125C4
	VGM6-160	VGM6160C3	VGM6160C4
	VGM6-250	VGM6250C3	VGM6250C4
	VGM6-400/630	VGM6***C3	VGM6***C4
	VGM6-800	VGM6800C3	VGM6800C4

***: 400 or 630

■ Interphase barriers

Interphase barriers	Frame size	3P(2pcs)	4P(3pcs)
	VGM6-125	VGM6125IB3	VGM6125IB4
	VGM6-160	VGM6160IB3	VGM6160IB4
	VGM6-250	VGM6250IB3	VGM6250IB4
	VGM6-400/630	VGM6***IB3	VGM6***IB4
	VGM6-800	VGM6800IB3	VGM6800IB4

***: 400 or 630

Accessories Selection Guide

■ Mechanical interlock

Mechanical interlock	Frame size	3P	4P
	VGM6-125	VGM6125MI3	VGM6125MI4
	VGM6-160	VGM6160MI3	VGM6160MI4
	VGM6-250	VGM6250MI3	VGM6250MI4
	VGM6-400/630	VGM6***MI3	VGM6***MI4
	VGM6-800	VGM6800MI3	VGM6800MI4

***: 400 or 630

■ Terminal cover

Terminal cover	Frame size	3P(2pcs)	4P(2pcs)
	VGM6-125	VGM6125TC3	VGM6125TC4
	VGM6-160	VGM6160TC3	VGM6160TC4
	VGM6-250	VGM6250TC3	VGM6250TC4
	VGM6-400/630	VGM6***TC3	VGM6***TC4
	VGM6-800	VGM6800TC3	VGM6800TC4

***: 400 or 630

■ Motor

Motor	Frame size	AC230V	AC400V	DC110V	DC220V	DC24V
	VGM6-125	VGM6125MAC2	VGM6125MAC3	VGM6125MDC1	VGM6125MDC2	VGM6125MDC3
	VGM6-160	VGM6160MAC2	VGM6160MAC3	VGM6160MDC1	VGM6160MDC2	VGM6160MDC3
	VGM6-250	VGM6250MAC2	VGM6250MAC3	VGM6250MDC1	VGM6250MDC2	VGM6250MDC3
	VGM6-400/630/800	VGM6***MAC2	VGM6***MAC3	VGM6***MDC1	VGM6***MDC2	VGM6***MDC3

***: 400 or 630 or 800

■ Round handle

Round handle	Frame size	Handle shape	Extended (Default 150mm)
	VGM6-125	Round	VGM6125HL1
	VGM6-160	Round	VGM6160HL1
	VGM6-250	Round	VGM6250HL1
	VGM6-400/630/800	Round	VGM6***HL1

***: 400 or 630 or 800

Note : Handle length of 300 & 600 mm are available on request.

MCCB With Spreader Link Dimension

Front connection

Note: All dimensions are in mm

VGM6/6s-125A 3 POLES & 4 POLES
VGM6

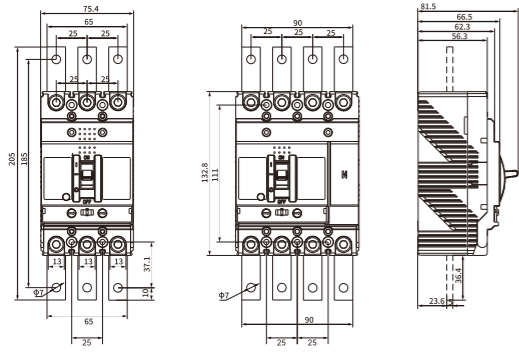

VGM6/6s/6sm-160A 3 POLES & 4 POLES

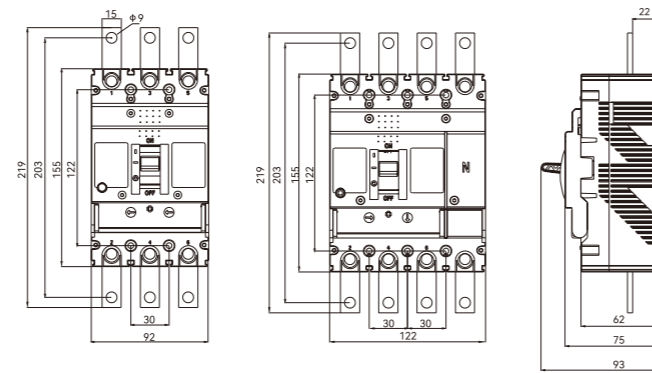

VGM6/6s/6sm/6E-250A 3 POLES & 4 POLES

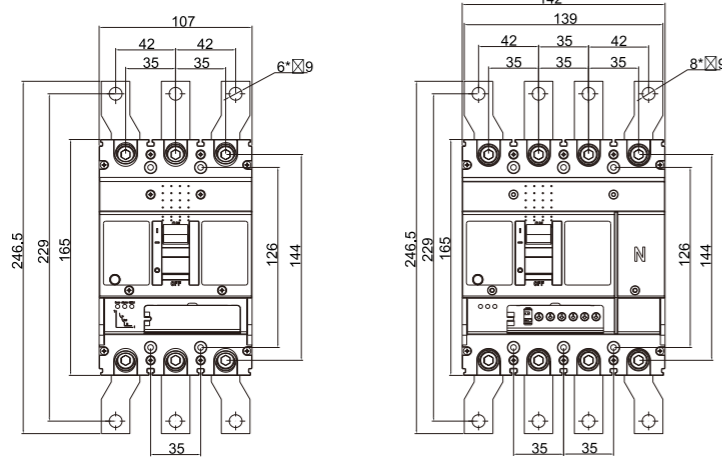

VGM6/6s/6sm-400A 3 POLES & 4 POLES

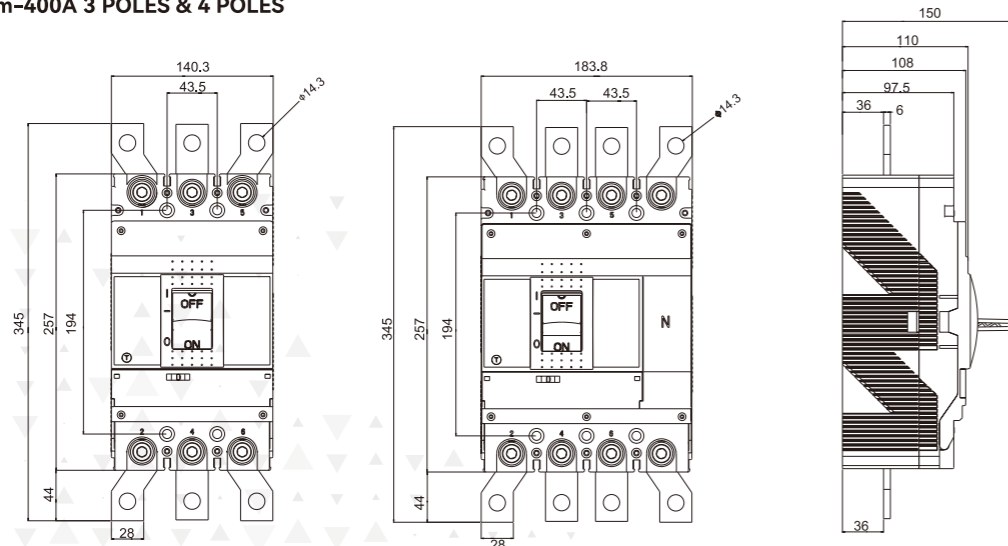

MCCB With Spreader Link Dimension

VGM6E-400A 3 POLES & 4 POLES

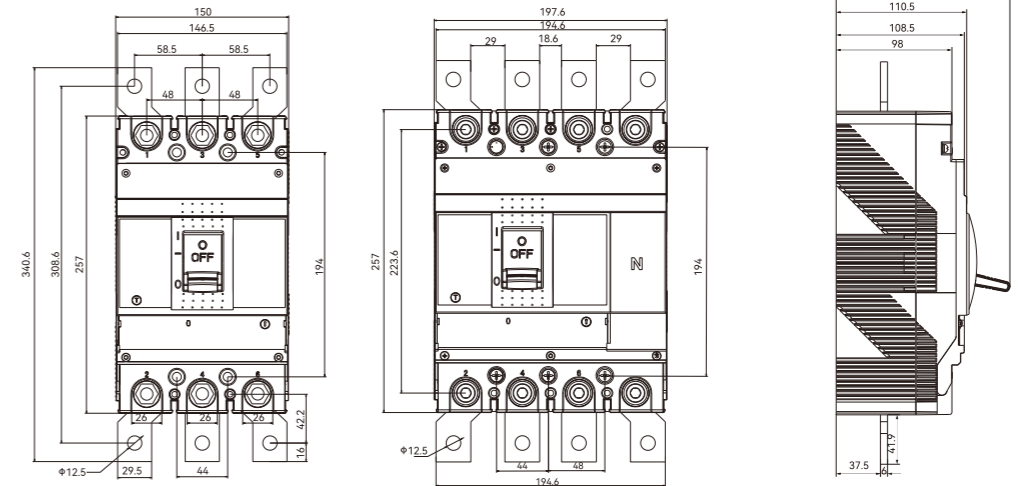

VGM6/6s/6sm/6E-630A 3 POLES & 4 POLES

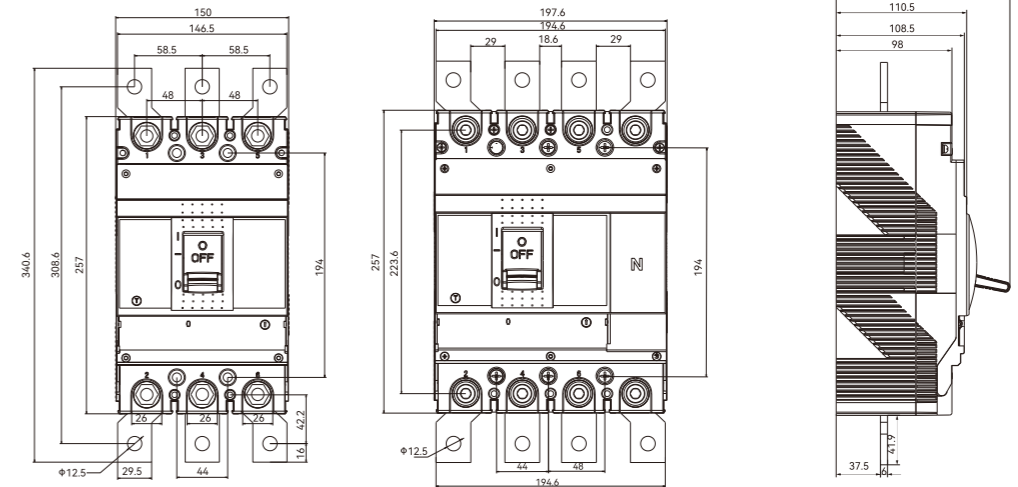

VGM6/6s/6sm/6E-800A 3 POLES & 4 POLES

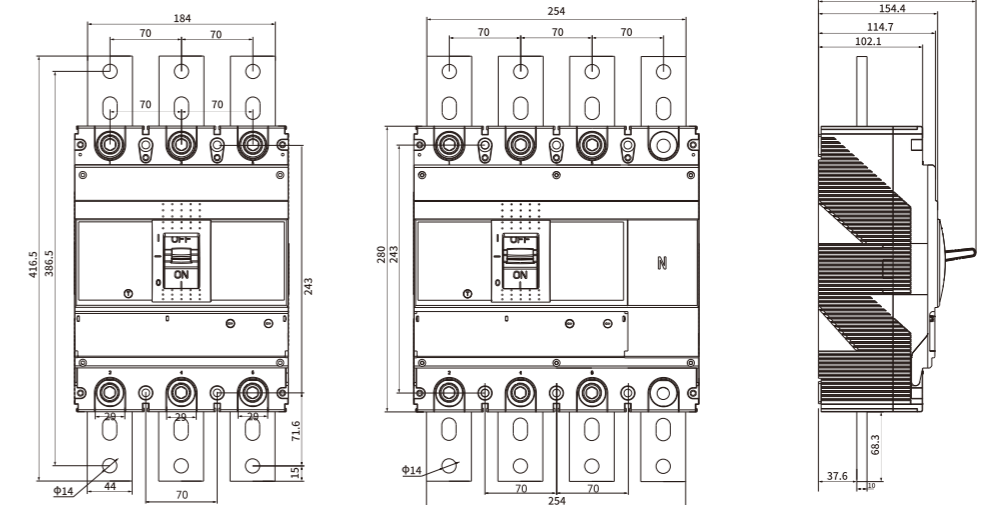

Plug-in MCCB Mounting Dimension

Front connection(mm)

Note: All dimensions are in mm

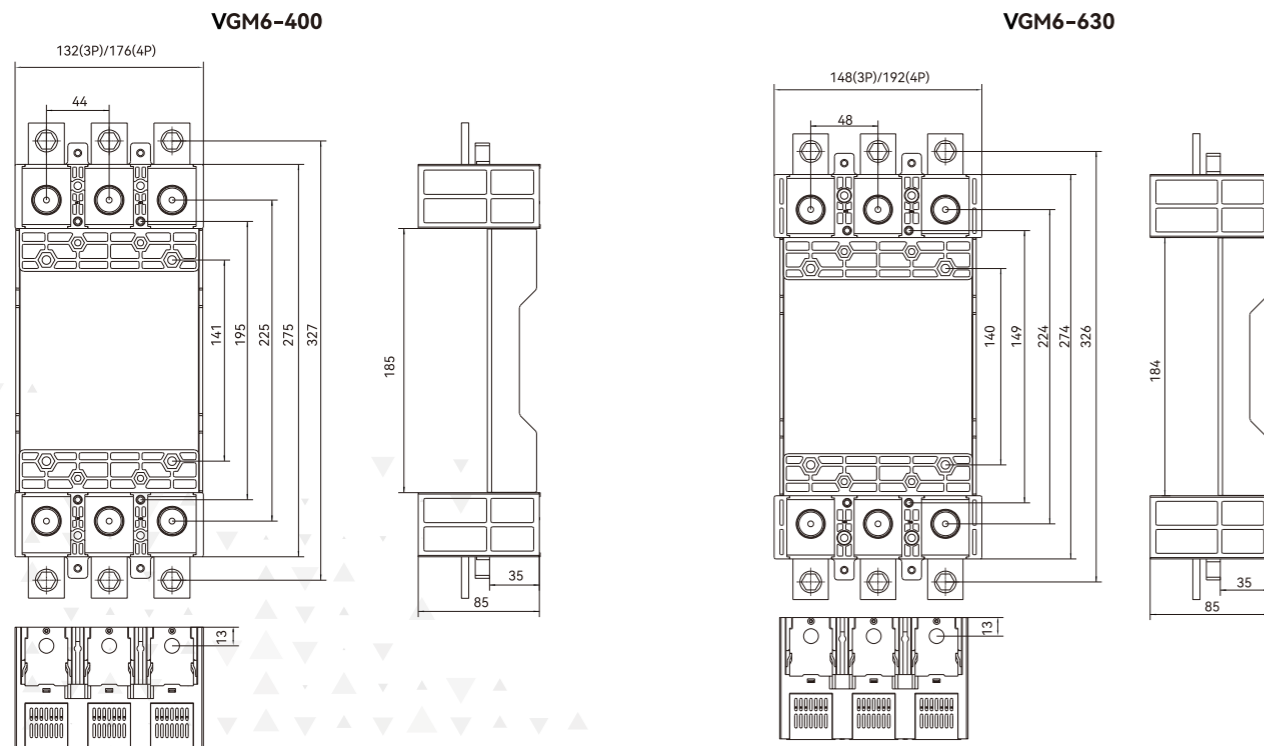
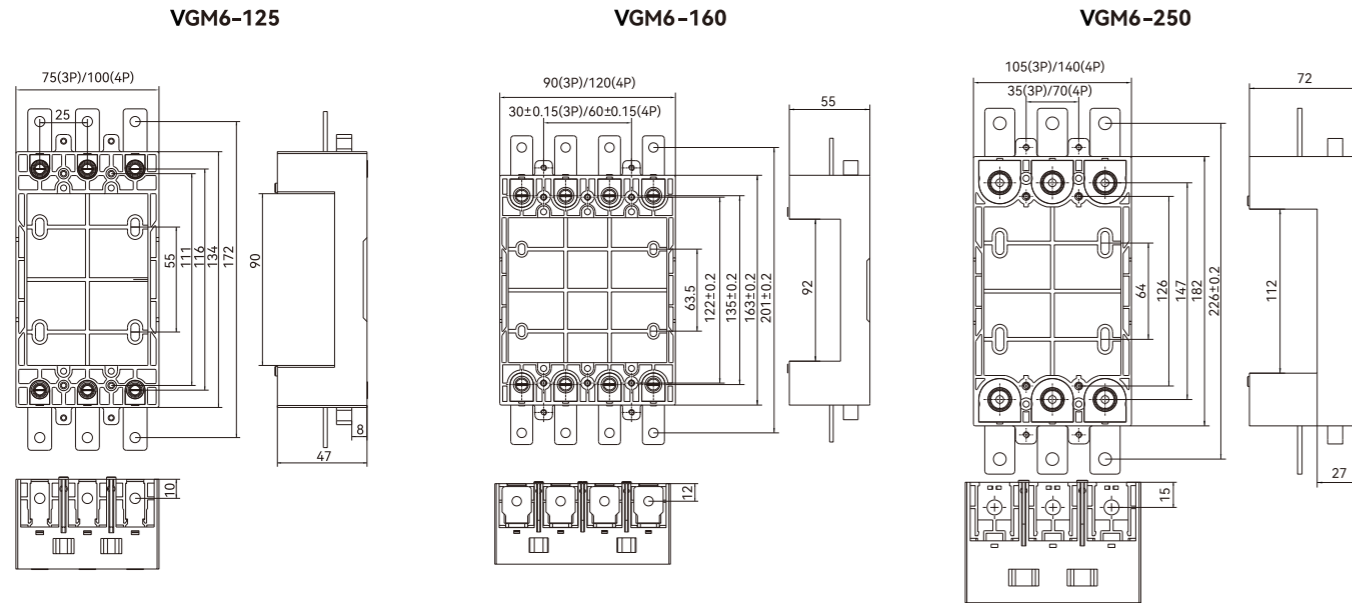

Rotary Handle Dimension

Mounting with MCCB dimensions(mm)

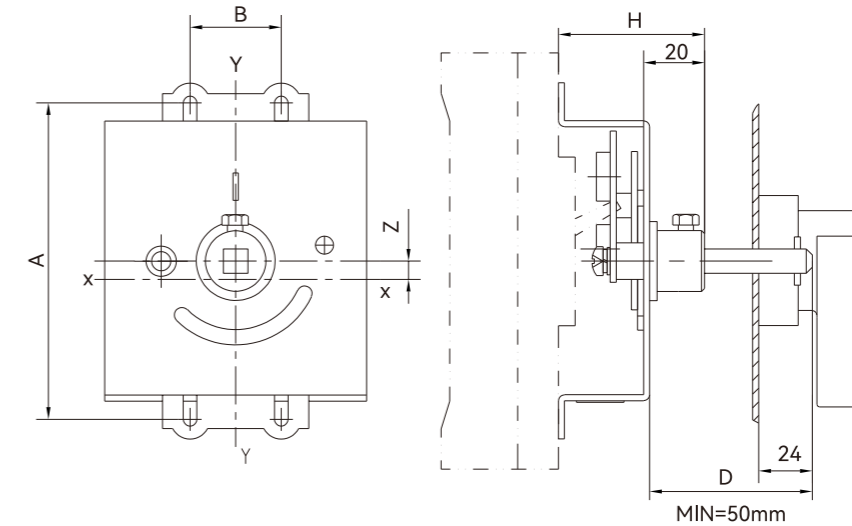

Model Number	Frame size	Installation dimensions		
		A	B	H
CS1-125/VGM6	VGM6-125	11	25	53
CS1-160/VGM6	VGM6-160	122	30	58
CS1-250/VGM6	VGM6-250	143	35	63
CS1-400/VGM6	VGM6-400/630	221.5	44	77

Handle and door cutting dimensions(mm)

Round handle dimensions

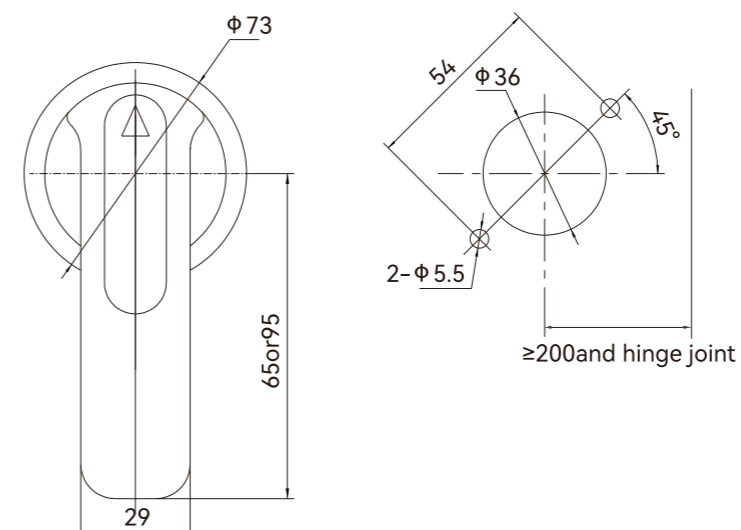

Frame size	A
VGM6-125	65/95
VGM6-160	65/95
VGM6-250	65/95
VGM6-400/630	65/95

Motor Mounted with MCCB Dimensions

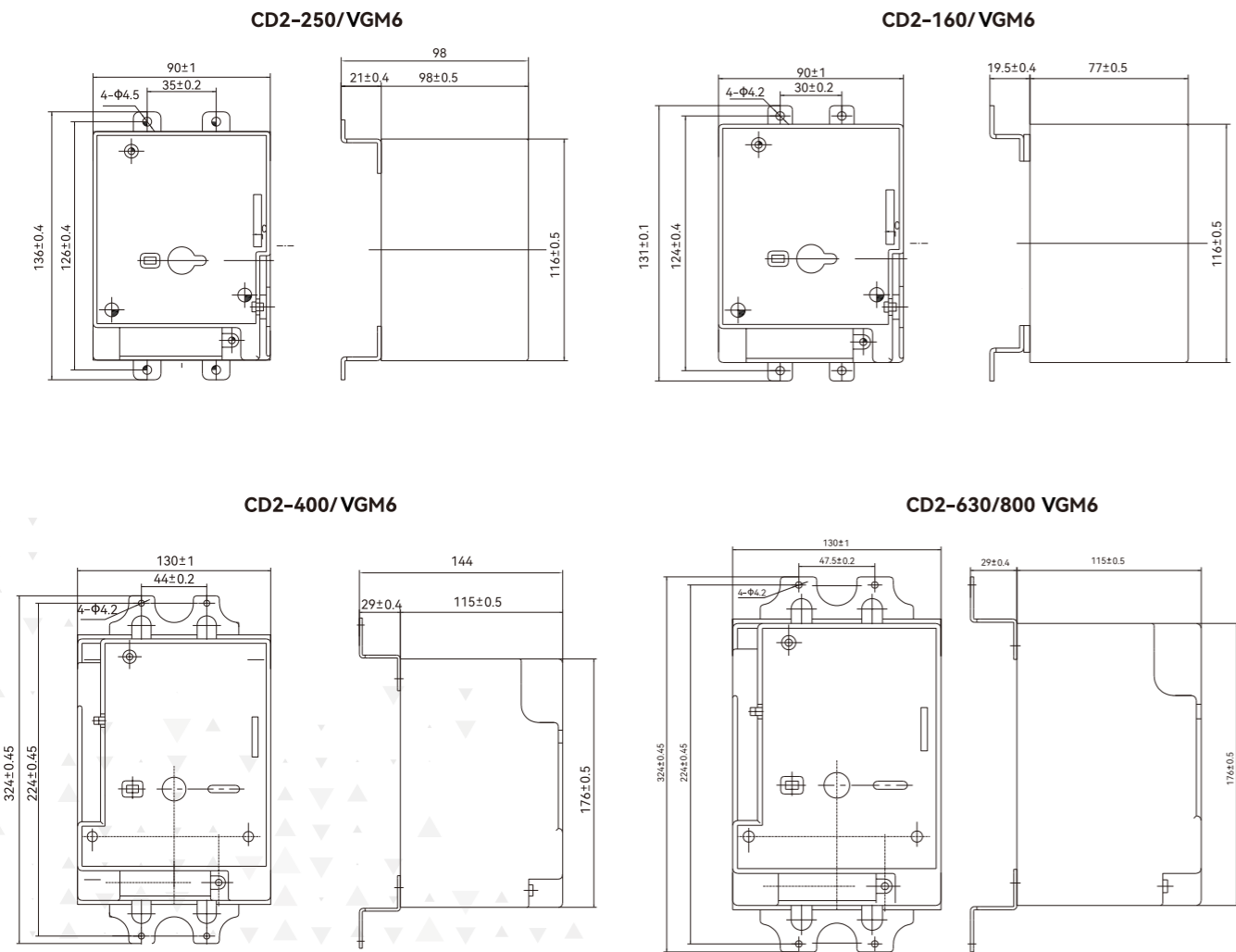
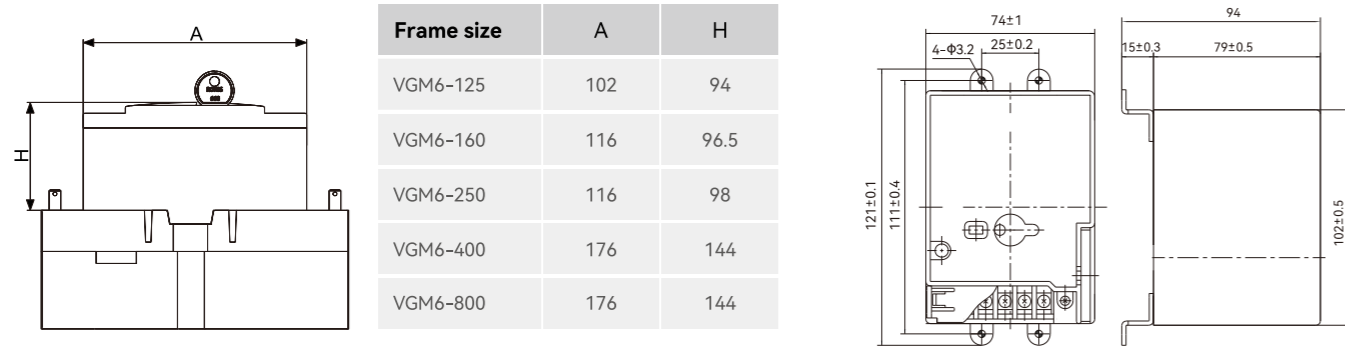

Attachment installation and lead direction

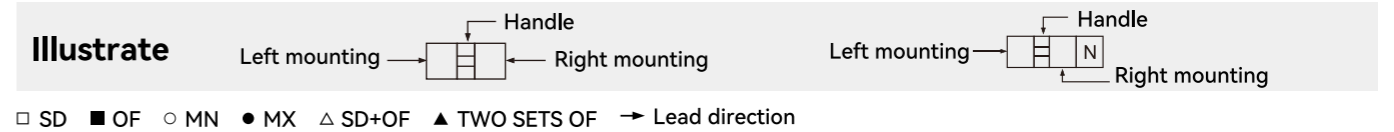

Item	Accessories	3P		4P	
		125A,160A,250A,400A,630A,800A		125A	160A,250A,400A,630A,800A
VGM6 (125-800A Frame)	SD				
	MX				
	OF				
	MN				
	SD+OF				
	TWO OF				
	MX,OF				
	MX,SD				
	MX,SD+OF				
	MX,TWO OF				
	MX,MN				
	MN,MX				
	MN,OF				
	MN,SD				
	MN,SD+OF				
	MN,TWO OF				
VGM6s (125-800A Frame)	OF,SD				
	OF,MX				
	OF,SD+OF				
	OF,WO OF				
	OF,MN				
	SD,OF				
	SD,MX				
	SD,SD+OF				
	SD,TWO OF				
	SD,MN				
	SD+OF,OF				
	SD+OF,SD				
	SD+OF,MX				
	SD+OF,TWO OF				
	SD+OF,MN				
	TWO OF,OF				
TWO OF,SD					
TWO OF,MX					
TWO OF,SD+OF					
TWO OF,MN					

Attachment installation and lead direction



OF (Auxiliary contact)



SD (Alarm switch)

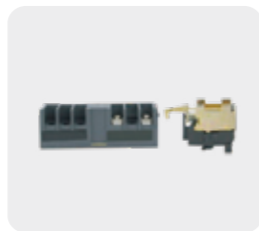

MX (Shunt trip)



MN (Under-voltage release)

Illustrate

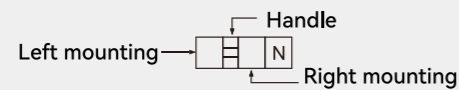

□ SD ■ OF ○ MN ● MX ▲ SD+OF ▲ TWO SETS OF → Lead direction

Item	Accessories	4P
		250A,400A,630A,800A
VGM6L	SD	→ □ □ □ □
	MX	→ ● □ □ □
	MN	→ ○ □ □ □
	OF	→ ■ □ □ □
	SD+OF	→ ▲ □ □ □

DC Moulded Case Circuit Breaker

Frame Size	 630
Model	VGM6 DC-630
Rated current(A) In	250,320,400,450,500,630
Number of poles	2
Standard	IEC60947-2
Reference temperature	40°C/55°C
Rated operational voltage	DC1500
Rated insulation voltage Ui (V)	1600
Rated impulse withstand voltage Uimp (kV)	12
Breaking capacity level	4
Rated ultimate short-circuit breaking capacity Icu(kA)	20
Rated service short-circuit breaking capacity Ics(kA)	16
Mechanical Endurance Electrical Endurance	5000 1000
Arcing distance	≤100
Dimensions mm(LxWxH)	98X310X130

High Voltage AC Moulded Case Circuit Breaker

Frame Size	 250		 630	
Model	VGM6 HU-250		VGM6 HU-630	
Rated current(A) In	125,140 160,180,200,225,250		400,500,630	
Standard	IEC60947-2			
Reference temperature	40°C/55°C			
Rated operational voltage	800/1000			
Rated insulation voltage Ui (V)	1140			
Rated impulse withstand voltage Uimp (kV)	8			
Breaking capacity level	L	M	L	M
Rated ultimate short-circuit breaking capacity Icu(kA)	12	36.5	12	30
Rated service short-circuit breaking capacity Ics(kA)	12	23	12	23
Mechanical Endurance Electrical Endurance	10000 5000		7000 3000	
Arcing distance	≤20		≤50	
Dimensions mm(LxWxH)	165X113X98.5		270X182X83	

Smart Moulded Case Circuit Breaker



Product Type and Function

Function Types	Intelligent	Network	
Protection Function	Over load	■	■
	Short Circuit	■	■
	Residual Current	■	■
	Auto Reclose	■	■
	Phase Loss	■	■
	Over Voltage	■	■
	Under Voltage	■	■
Measurement and Display	Residual Current Auto Test	■	■
	Three phase voltage	■	■
	Three phase current	■	■
Characteristics Setup	Rated Residual Current	■	■
	Overload Time Delay	■	■
	Short Circuit Time Delay	■	■
	Instantaneous Short Circuit	■	■
	Over voltage Value	■	■
	Under voltage Value	■	■
	Time,Date	■	■
Info Restore,Check and Display	Protection In & Out	■	■
	Residual Current Trip	■	■
Communication	RS-485	■	■
	DLT 645	■	■

Smart Moulded Case Circuit Breaker

Specification & Type	VGM3EL-125CY	VGM3EL-250CY	VGM3EL-400/630CY	VGM3EL-800CY	
Set up value	40A,50A,63A,80A 100A,125A	100A,125A,140A 160A,180A,200A 225A,250A	200A,225A,250A 315A,350A,400A 500A 630A	400A, 500A,630A 700A,800A	
Poles	3P+N	3P+N,2P	3P+N	3P+N	
Case Current Ue(V)	AC400/50HZ		AC400/50HZ		
Rated insulation Voltage Ui (V)	AC 800V		AC 800V		
Rated Withstand Voltage Uimp (V)	800		8000		
Arc Distance	≥50		≥100		
Rated short circuit breaking capacity (Icu)	50		65		
Operation short circuit breaking capacity (Ics)	35		42		
Rated Residual Short Circuit Breaking Capacity (kA)	12.5		20		
Time delay setup value TI	3s,4s,6s,8s,10s,12s,16s,18s, OFF				
Residual Current Trip Characteristics	AC type		AC type		
Rated Residual Trip Current I _{Δn} (mA)	50/100/200/400/600/800 Auto trace or manual setup		100/200/300/500/800/1000 Auto trace or manual setup		
Residual Trip Time Characteristics	Time Delay / Non Time Delay				
Time Delay Limit Un- DriveTime(S)	0.06/0.1/0.2 Select:2 I _{an}				
Auto Reclose Time (s)	20-60				
Operation Characterises (times)	Power On	1500	1000	1000	1000
	Power Off	8500	7000	4000	4000
	Total Trips	10000	8000	5000	5000
Overload , Short circuit Characteristics	Three steps protection , electronic adjust, see more on " Protection Characteristics Instruction"				
Over Voltage Value (V)	Setup Value(250-300)± 5%				
Under Voltage Value (V)	Setup Value(150~ 200)± 5%				
Connect Control Time (ms)	≤40ms				
Communication Delay Time(ms)	≤200ms				